

# Assembly Instructions for inner and outer letter plate

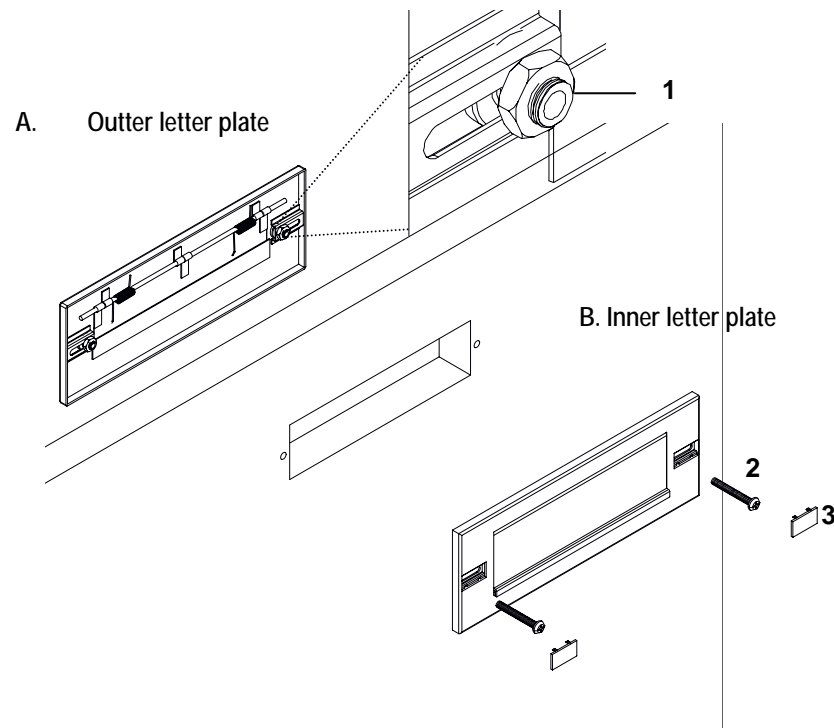

1. The opening slot in the door has to be 230mm x 60mm to allow smooth operation of the letter plate flap.
2. Drill two holes ( $\varnothing$  7mm) horizontally through the door at the required interval (247-280mm).
3. Set the distance of the threaded retainers (2) so that they correspond with the existing door drills and fix it with the hex nut (5)
5. Insert the M6 screws (2) through inner letter plate and the door in the threaded retainers (2).
6. Put the clip on the inner plate, to hide the screws. .
7. Check for smooth operation