

Installation Instructions for Double Cylinder Deadbolts

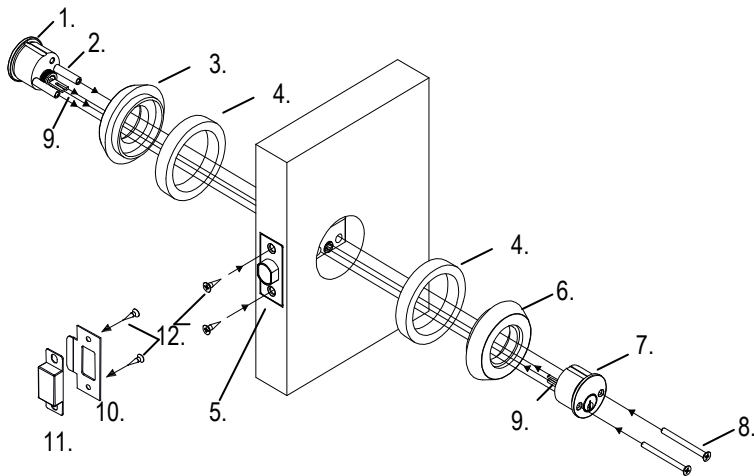

1. Outside cylinder
2. Sleeves with inner thread
3. Outside cylinder collar
4. Distance ring for thin doors (optional)
5. Latch
6. Inside Cylinder Collar
7. Inside Cylinder
8. Cylinder Screws
9. Tailpieces of cylinders
10. Strike Plate
11. Dust Cover
12. Wood screws

1. Door preparation

- Draw a level 3" (76mm) center line on both sides of the door. The standard height for a handle set is 36" (914mm) from finished floor. Please adjust the deadbolt height as you like.
- Fold template over edge of door, mark site 2 3/8" (60mm) or 2 3/4" (70mm) to determine the center point of holes.
- Please pay attention to the different door thickness and also different center line.
- Drill a 2 1/8" (54mm) hole half way through the door on each side to prevent splintering of door. Where the door is marked for the center of the latch, drill a 1" (26mm) hole.
- Cut out a 2 9/32" x 1" x 1/8" (58x26x3mm) base.
- Latch doesn't take the bevel of the door into account.
- Bore from the lower end of the bevel to allow for this.

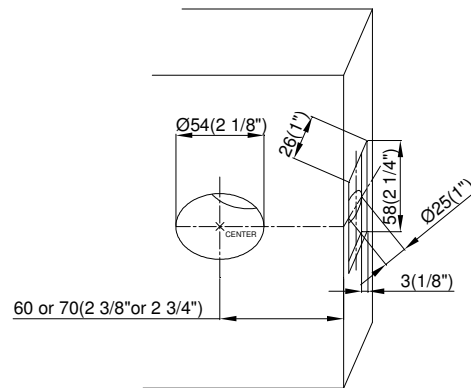
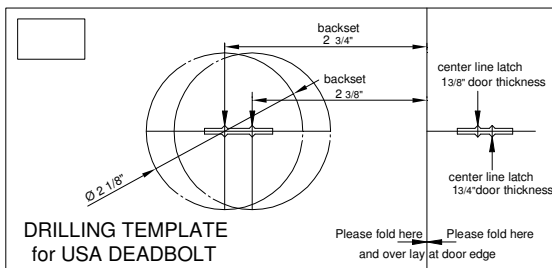

2. Installation of latch

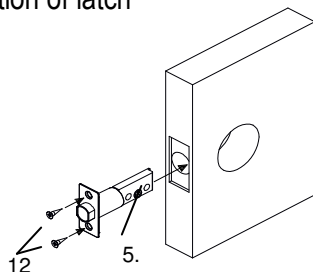

Install latch (5) using wood screws (12) provided.

3. Fixture of the Double Cylinder Deadbolt

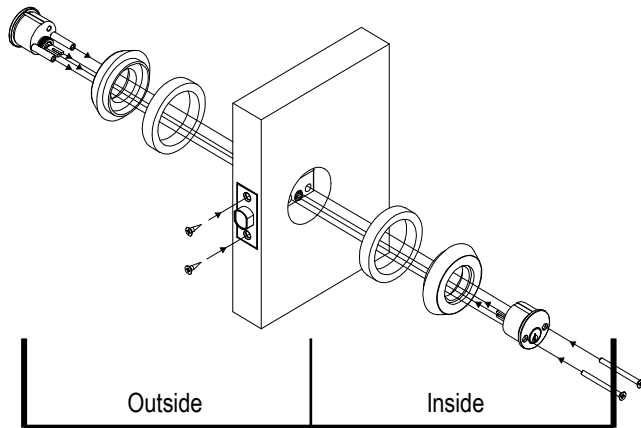

Outside:

Insert outside cylinder (1) through collar (3) into latch (5).

Pay attention that the tailpiece (9) of the **outside** cylinder is inserted **horizontally**

Inside:

Insert the inside cylinder (7) through the collar (6) into the latch.

Pay attention that the tailpiece (9) of the **inside** cylinder is inserted **vertically**.

Insert the cylinder screws through inside cylinder, through the latch into the sleeves with inner treads. Tighten cylinder screws (8).

Please make a functional test

Optional: Use one or two distance rings (3) for thin doors

Choose cylinder screws for different door thickness

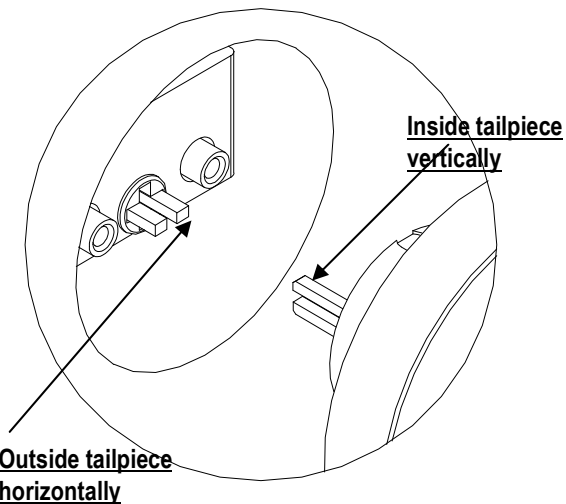

Door Thickness	Screws	Distance rings
1 3/8" - 1 3/4" (35-45mm)	M4 X 55	2
1 13/46" - 2 5/16" (46-59mm)	M4 x 55	1
2 3/8"-2 3/4" (60-70mm)	M4 x 55	none

4. Installation of strike

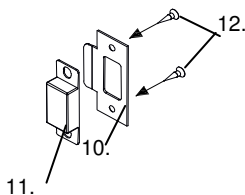

- Mark the position of the latch throw at the door frame for the strike plate location.

- Using the strike plate (10) as a template outline the position in pencil.

- Prior to installing the strike plate chisel a 1 1/16" (27mm) high, 7/8" (22.225mm) wide and 1 3/16" (30mm) deep hole into the door frame for the plastic dust cover (11). Chisel door frame to fit strike plate (10) flush approximately 1/8" (3.175mm) in depth.

- Install dust cover (11) and strike plate (10) using supplied wood screws (12).

Limited Warranty

Karcher GmbH ("Karcher") warrants to the original retail purchaser ("Purchaser"), but to no other person, that Karcher's products ("Products") shall be free from defects in material or workmanship for a period of one (1) year following the purchase of the Products from an authorized dealer. Karcher's sole obligation under this limited warranty shall be, at the option of Karcher, to repair or replace Products which Karcher determines, in its sole discretion, to be defective and which are returned to Karcher by an authorized dealer within one (1) year from the date of purchase of the Products.

Karcher does not assume any warranty responsibility for damage to the Products due to conditions over which Karcher has no control, including but not limited to ordinary wear and tear, improper installation or maintenance, alteration, impact, accident, misuse, tampering or abuse. Karcher assumes no responsibility for tarnishing, discoloration, excessive wear or deterioration of the surface finishes due to exposure to weather conditions over which Karcher has no control. Karcher assumes no responsibility for any defects or damage caused by the Purchaser or any third parties.

KARCHER MAKES NO OTHER WARRANTIES OF ANY KIND OTHER THAN THOSE CONTAINED HEREIN AND HEREBY DISCLAIMS ALL OTHER WARRANTIES, EXPRESS OR IMPLIED, WITH RESPECT TO THE PRODUCTS INCLUDING WITHOUT LIMITATION ANY WARRANTIES OF MERCHANTABILITY OR FITNESS FOR A PARTICULAR PURPOSE. THIS LIMITED WARRANTY IS IN LIEU OF ALL OTHER WARRANTIES, EXPRESS OR IMPLIED, AND IS LIMITED TO THE DURATION OF THE LIMITED WARRANTY PERIOD. IN NO EVENT SHALL KARCHER BE LIABLE FOR ANY SPECIAL, DIRECT INDIRECT, INCIDENTAL, OR CONSEQUENTIAL DAMAGES, INCLUDING, BUT NOT LIMITED TO LOSS OF PROFITS, PROPERTY DAMAGE, DAMAGES TO BUSINESS OR BUSINESS RELATIONS, OR DAMAGES FOR LOSS OF OPERATION. THIS WARRANTY REPRESENTS KARCHER'S SOLE LIABILITY TO THE PURCHASER FOR CLAIMS RELATED TO THE PRODUCTS WHETHER THE CLAIMS ARE BASED UPON CONTRACT, TORT, OR ANY OTHER LEGAL THEORY. Karcher's total cumulative liability under this limited warranty, if any, is limited to the dollar amount of the Purchaser's original payment for the Products.

The invalidity or unenforceability of any provision of this limited warranty shall not affect the validity and enforceability of any remaining provisions, and this limited warranty and disclaimer of liability shall be construed in all respects as if any invalid or unenforceable provision is omitted.

Some states do not allow limitation on how long an implied warranty lasts or the exclusion or limitation of incidental or consequential damages so the above limitations or exclusions may not apply to you, the buyer.

This warranty gives you specific legal rights and may also have other rights which vary from state to state.